



WORLD NO. 1 IN HYDRAULIC  
ELEVATOR TECHNOLOGY

More than **830,000 lifts** worldwide  
with **GMV technology**



# LCHL

## LOW COST HOME LIFT

2 STOPS, STANDARD SINGLE PHASE OPERATION, WITH GMV MICRO SIZE CONTROLLER



[www.gmv.it](http://www.gmv.it)  
[www.gmv-india.co.in](http://www.gmv-india.co.in)

# LOW COST HOME LIFT LCHL (G+1)

## > COMFORT

The only Home Lift in the market with a MRL Solution (Machine Room Less) GMV valve and with bio-degradable eco-fluid.

Available with adjustable speeds.

Max. speed upto 0.3m/s (optional)

Caution: Speed >0.15m/s To 0.25m/s

## > SAFETY AND FULLY COMPLIANT WITH THE STANDARDS

It meets EN 81.70 standards (accessibility).

Equipped with ARD Safety function

## > AVAILABLE MOTORS AND VOLTAGES

Single-phase

## > SELF-SUPPORTING STRUCTURES (optional)

Easy to install. **Installation time of just 3 days**

## > SHAFT

Optimal use of shaft space

## > HIGH ENERGY EFFICIENCY

Low Energy consumption (in compliance with Kyoto Protocol).  
The energy used is like that of a 230V standard house hold appliance.

## > ENVIRONMENTLY FRIENDLY

It can be used with bio-degradable Eco-fluid

## > FLEXIBILITY

It can be 100% customized for cabin & Door designs

Adaptable to each customers requirement

- Wide range of doors available: power-operated, hinged semi-automatic, manual landing doors with the same finishes as the apartment doors, etc.
- Wide range of aesthetic finishes

Front Page\* -MS Cabin & manual Swing Door (Powder Coated), Ex works, Without Taxes, Without Installation, without Testing & Comissioning  
\*\* Optional at additional cost



# LOW COST HOME LIFT FEATURES

## TECHNICAL FEATURES

<b>Suspension</b>	Direct Acting
<b>Payload</b>	204 Kgs – 272 Kgs
<b>Max. n° of passengers</b>	4
<b>Max. number of stops</b>	2 Stops (G+1)
<b>Max. travel</b>	3200 mm
<b>Max. speed</b>	0.15mps / 0.25 mps
<b>Motor power</b>	2.9 kW – 4.5 kW
<b>Min. pit</b>	130 mm
<b>Min. headroom</b>	2500 mm
<b>Lift car</b> <small>(standard sizes)</small>	Please refer Page no. 14 & 15
<b>Cabinet</b> <small>(optional)</small>	Please refer Page no. 9 (except Glass Cabin)
<b>Energy efficiency</b>	The used energy is like that of the most common household appliances
<b>Fluid</b>	Eco-fluid (Optional)
<b>Standard</b>	EN 81.41



\* Speed up to 0,3 m/s, without certificate and only outside the European Market

## STANDARD EQUIPMENT

### > HYDRAULIC POWER UNIT

- Power unit HL or HLV with mechanical valve or, as an option, with NGV electronic valve, that provides higher safety and energy efficiency
- Reduced energy consumption thanks to its outer motors (DRY).
- Double safety system incorporated as standard.
- Leveling and electrical emergency system.
- One stage jack (1008 SL piston).
- Hydraulic equipment calculated according EN 81-20 standard.
- Flexible hose.
- Travel comfort: programming upwards speed independent from the down speed.

### > MECHANICAL EQUIPMENT

- Car frame 2:1 (T509 model).
- Instantaneous safety devices to increase safety.
- Deviation pulley and traction cables.
- Pillars and stand base.
- Mechanical device to perform the trial test for the rupture valve.
- Guide rail type T82, 5000 mm long

### > ELECTRICAL EQUIPMENT

- Automatic push-button or constant pressure controller
- EMC certificate
- Pre-wired cables (plug in play). Automatic return to floor.
- Single-phase motor 50/60 Hz. Car light timer.

### > LANDING DOORS

- Hinged semi-automatic doors.
- Certified door locks.



## STANDARD

### EQUIPMENT IN COMPLIANCE WITH EN.81.41 (safety)

- Pressure switch
- Interphone or intercom inside the car
- Hand pump
- Hold-to-run operation
- Handrail
- Light curtain as per EN.81.41
- Specific information labels as per EN.81.41
- Safety device for reduced pit
- Door clear width: 800 mm
- Lift car sizes as per EN.81.41
- Set of electrical switches

### EQUIPMENT IN COMPLIANCE WITH EN.81.70 (accessibility)

- Door clear width minimum of 700 mm
- Horizontally sliding car and landing power operated doors
- Side handrail
- Half wall mirror
- Precise floor leveling +/- 10 mm
- Push button boxes as per EN.81.70
- Vocal indicator at floor arrival, acoustic and visual indicators
- LCD Display with your personal Album \*\*

\* Possibility of extending the warranty up to 10 years. For further information please call the phone number overleaf



  
Home Lifty

## SAFETY

### > Safety devices:

- Instantaneous safety device to increase safety
- Pipe bursting valve with CE certificate
- Device for reduced pit for the maintenance phase.
- Visual and acoustic overload indicator
- Light curtain at each entrance

### > Electrical equipment:

- Push button box at every floor
- Emergency stop push button
- Alarm push button
- Emergency light

## QUALITY

### > List of the available certificates:

- EMC certificate for the controller and the NGV electronic valve block
- Certificate for fire-rated landing doors
- EC certificate for: pipe bursting valve, landing door locks and Safety devices in the car frame

### > Standards:

- Machine Directive 2006/42/EC
- EN.81.41 and EN.81.70 (optional)
- EN.81.58



# FINISHES, COLOURS, MATERIALS FLOORS & CEILINGS

## FLOORS - PVC

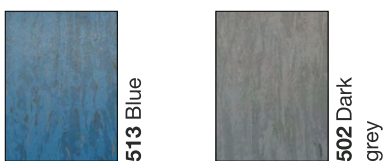

## FLOORS - PVC (anti slip floor)

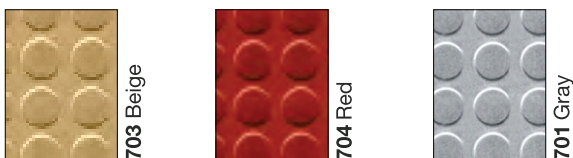

The Lift car floor can be prepared with 20 mm undercut to allow the customer to fit their own lining.

GMV offers two different types of lighting available with any car dimension:

## NEON Ceilings



Curved plexiglass (standard)



Domino\*



Bubbles\*

## LED Ceilings

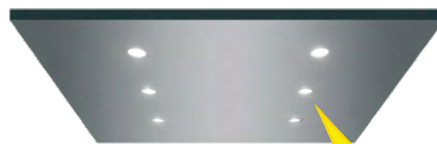

Led\*

 301 SB stainless steel

\* The finishes of all models are in stainless steel.

**False ceiling of  
any design of  
your choice**

# FINISHES, COLOURS, MATERIALS WALLS

## PLASTIC LAMINATE



**114** White  
light blue



**115** Stone  
grey



**116** Carob



**117** Lavender

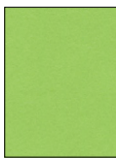

**118** Green



**119** Yellow



**120** Orange

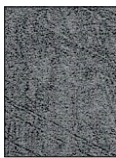

**121**  
Copperfield



**123** Brushed  
silver



**125** Manganite



**126** Durmast

## STAINLESS STEEL

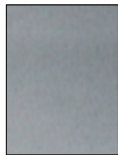

**301** SB  
stainless steel



**302** Stainless  
steel chequers

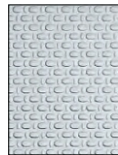

**303** Stainless  
steel linen



**304** Stainless  
steel leather

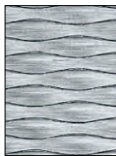

**305** 5WL

## SKINPLATE

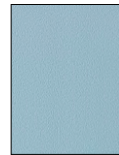

**416** Light blue



**417** Dark blue



**422** Pink  
marble

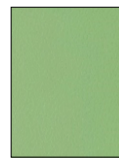

**418** Dark  
green



**413** Dark  
grey

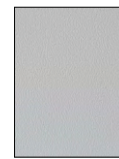

**412** Light  
grey



**414** Satin



**420** Glossy  
white marble

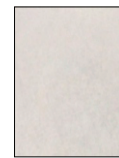

**421** Glossy  
beige marble



**419** Red



**409** Fir



**410** Mahogany

## GLASS

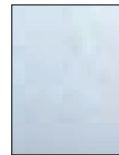

**801** Glass

# FINISHES, COLOURS, MATERIALS **DOORS**

## DOOR TYPES



**2AT** Telescopic doors



**3AT** Telescopic doors



**2AO** central opening doors



Hinged doors – on floors

## CAR AND LANDING DOORS\*

<b>PLASTIC LAMINATE</b>	Please contact GMV sales office
<b>SKINPLATE</b>	Telescopic / central opening doors only
<b>STAINLESS STEEL</b>	All types available
<b>GLASS</b>	Available finish
<b>RAL</b>	Hinged doors

\* Finishes like car walls (see page 9)

## POLIMOD (automatic doors only)

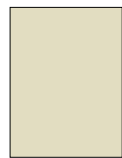

**201** Beige



**204** Light  
grey



**205** Dark  
grey

## CAR AND DOORS OPTIONS

NOTE: For other options please call the GMV sales office



Ceiling: curved plexiglass and Neon lighting



Half wall mirror



Full wall mirror



Stainless steel handrail



Display in landing and car push button boxes



Car doors: telescopic / central opening doors 2AT/2AO/3AT



Car doors: Power operated bus doors

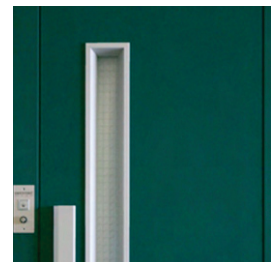

Landing doors with any RAL finish



Telephone (arrangement only)



Intercom



Ceiling: stainless steel and Led lighting

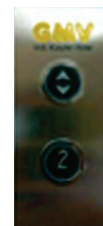

Customized logo



Key in car

### ADDITIONAL OPTIONS



NGV programming tool



Eco-fluid

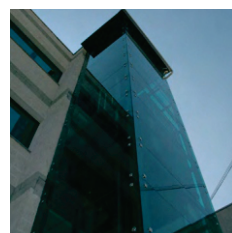

Self-supporting structures for indoor and outdoor

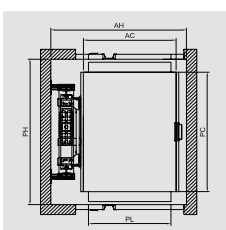

2 entrances

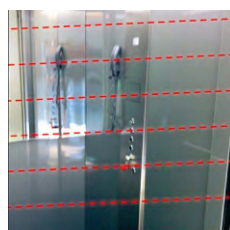

Light curtain

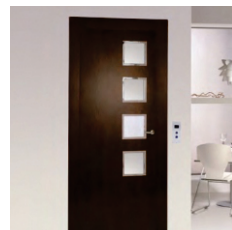

Use the finishes of your house doors for your Home Lifty door

### OTHER ADDITIONAL OPTIONS

- Door clear width different from the standard
- Door clear height different from the standard (2000 mm)
- Guide rails 2500 mm long
- Automatic system for hinged doors
- Remote control

# HOME LIFTY MRL-MC VERSION

## Structure

GMV can provide steel structures for indoor or outdoor use, with any possible finish (steel or glass), perfectly matching any new or existing building type. The technical structure specifications are calculated depending on each installation, in compliance with any national standard or regulation.

## Landing doors

Door models available: power operated doors 2AT-2AO-3AT, hinged doors (Car bus door and manual at landings), Manual doors (without car door). Available finishes: Polimod, Plastic laminate, Plastic coated sheet steel (Skinplate), Stainless Steel, Panoramic glass or RAL painted. Quick and easy to assemble and adjust.

## 1008 SL piston

Maximum shaft optimization. Less fluid quantity used. Quick and easy to install thanks to its design.

## Car

Designed to fit into any furnishing type. Car wall panels available in Skinplate, Plastic Laminate or Stainless Steel. Several ornamental solutions are possible. Very robust floor and roof. Car lighting available with led or fluorescent neon tubes. Easy access to the shaft through a hatch in the car roof.

## Flexible hose

Designed with inner synthetic rubber coat, with one or two high resistance spirals. The outer layer of synthetic rubber provides excellent resistance.

## Eco-fluid

It guarantees the best results and very high performance over the years. It betters the performance of the NGV valve. Best filtration with or without water. Excellent anti-corrosion, anti-oxidant and anti-foam results. Very low freezing point.

## Car frame T509

Traction 2:1. Designed for any kind of building thanks to the reduced pit (150 mm). Ideal to transport passengers in single family installations. It is supplied with a low pit safety device according to EN 81.41.

## Car doors

Available door types: Power operated (2AT- 2AO - 3AT). Semiautomatic (bus door in car and manual landing door). Without car door (with light curtain technology)

## Control panel

Easy to install, setting at work and maintenance with LED signal inputs and output indicators-LCD display. Robust push-buttons. Diagnostic tool provided for installation, parameter settings, repair and, maintenance, allowing to find code errors.

Furthermore it supplies:

- Automatic re-leveling
- Emergency lowering device to main floor in case of black-out
- Automatic push-button or constant pressure controller
- Car light timer

## Cabinet

Cabinet of reduced dimensions that can be located anywhere at home within a radius of approximately 15 m.

## Power unit

Power unit located in a machine room or, thanks to its reduced size, anywhere to optimize the housing space. The power unit can be equipped with NGV electronic valve.

Very high comfort and very low consumption thanks to its outer motor (DRY).It complies with the Machine Directive 2006/42/EC.

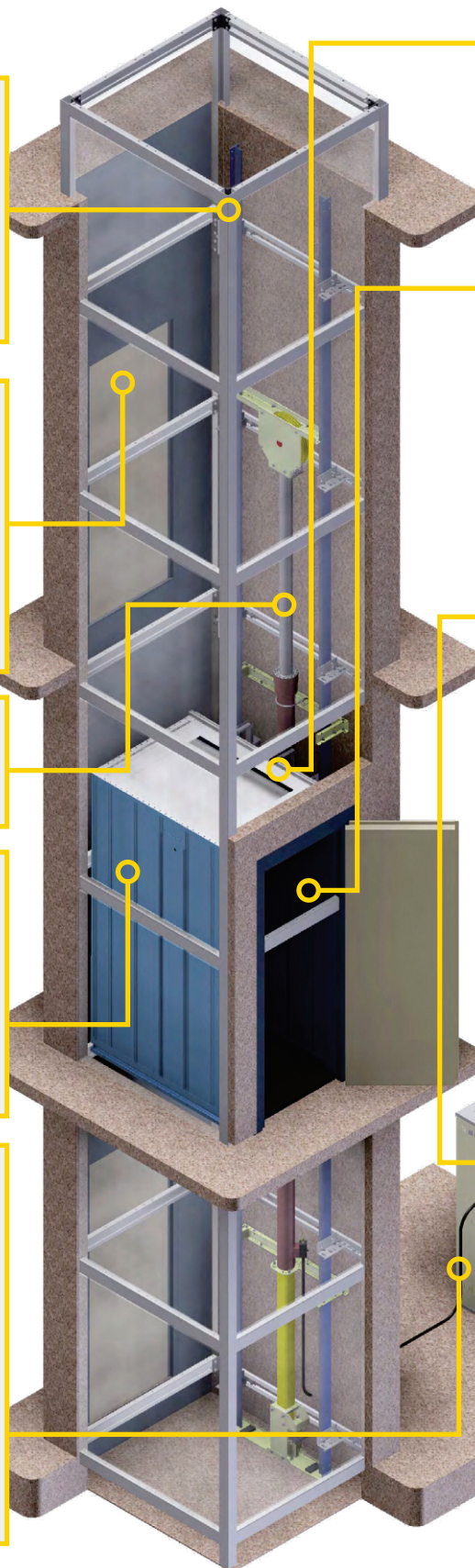

\*Image for representation only. Kindly consider (G+1) 2 stops only.

# HOME LIFTY MRL VERSION

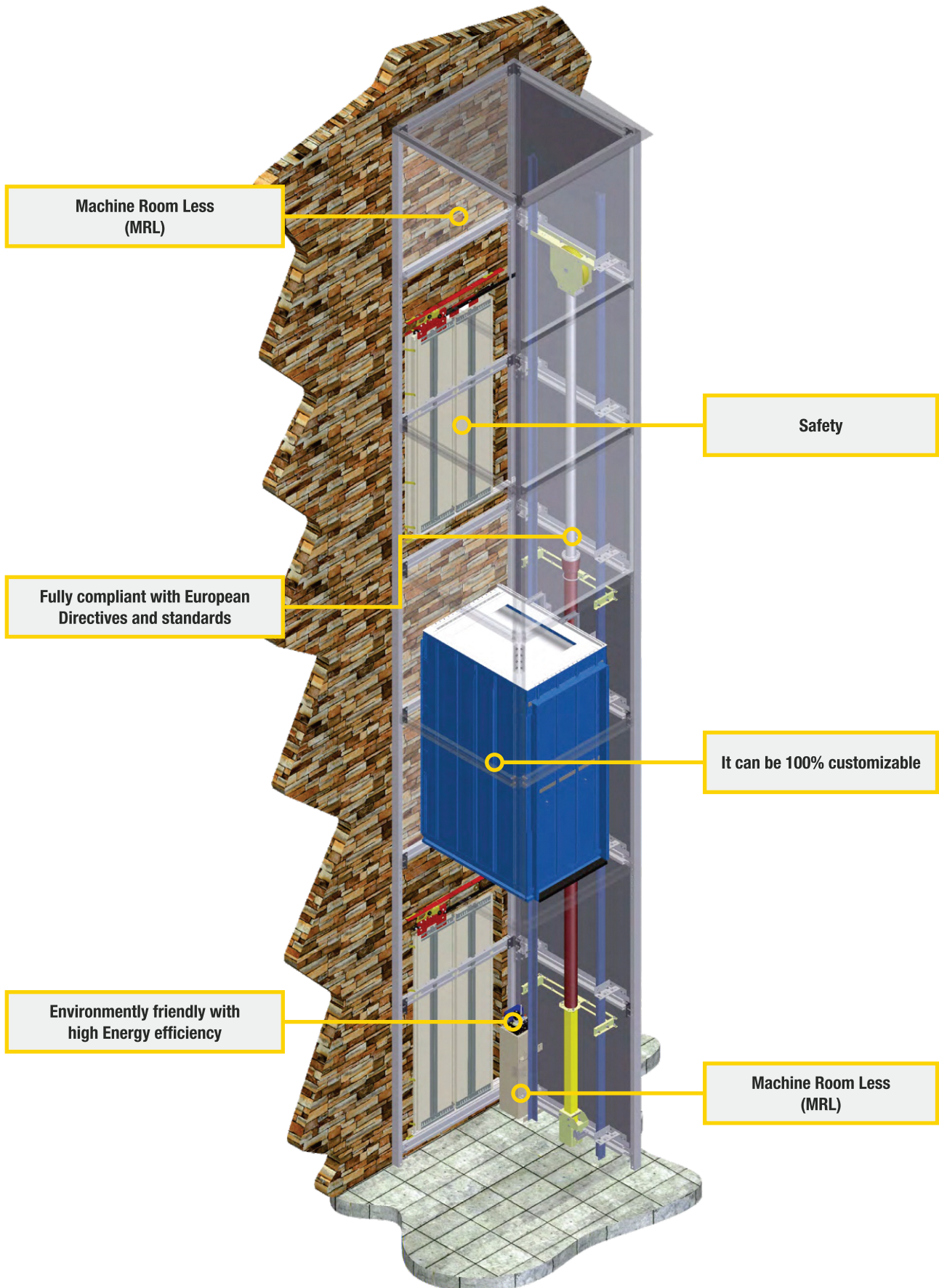

\*Image for representation only. Kindly consider (G+1) 2 stops only.

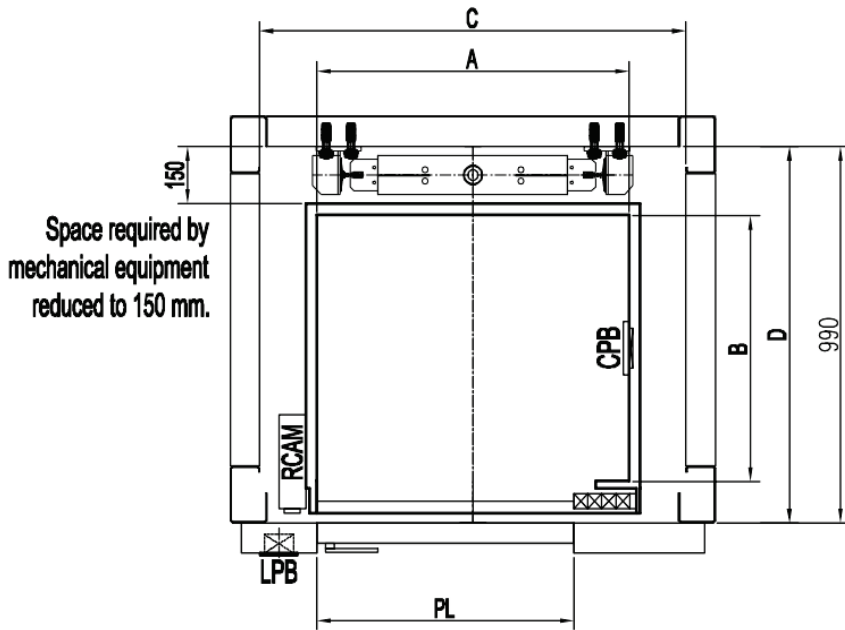

Payload [kg]	No. Pass	Car dimensions [mm]	Clear door opening [mm]	dimensions with Swing landing doors -Car Collapsible opening doors [mm]
		A x B	PL	C x D
204	3	850 x 700	700	1160 x 990

- Minimum pit 130 mm.
- Minimum headroom 2500 mm.

Shaft dimensions for Manual Swing door type – 3 Passenger

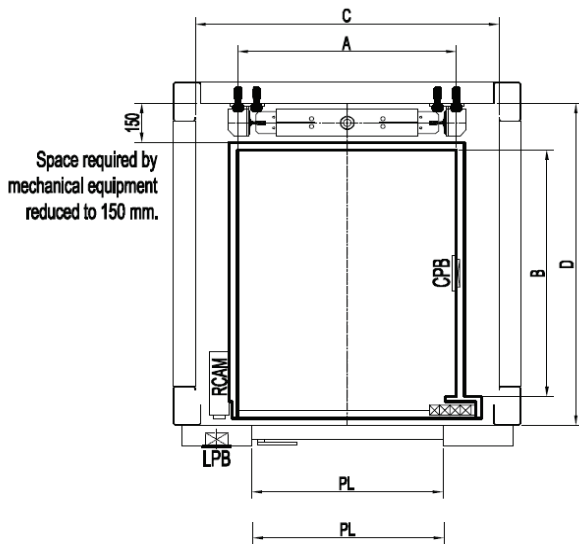

Payload [kg]	No. Pass	Car dimensions [mm]	Clear door opening [mm]	dimensions with Swing landing doors -Car Collapsible opening doors [mm]
		A x B	PL	C x D
272	4	800 x 950	700	1110 x 1240

- Minimum pit 130 mm.
- Minimum headroom 2500 mm.
- Minimum headroom 2500 mm.

Shaft dimensions for Manual Swing door type – 4 Passenger

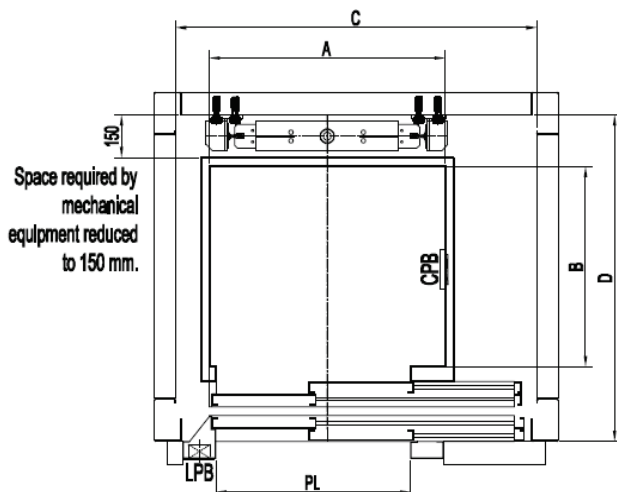

Payload [kg]	No. Pass	Car dimensions [mm]	Clear door opening [mm]	dimensions with Telescopic opening doors [mm]
		A x B	PL	C x D
204	3	850 x 700	700	1300 x 1140

- Minimum pit 130 mm.
- Minimum headroom 2500 mm.

Shaft dimensions for Auto Telescopic door type – 3 Passenger

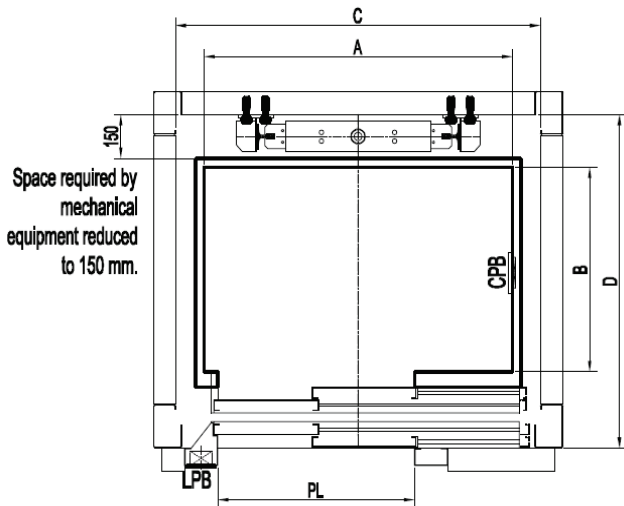

Payload [kg]	No. Pass	Car dimensions [mm]	Clear door opening [mm]	dimensions with Telescopic opening doors [mm]
		A x B	PL	C x D
272	4	1100 x 700	700	1300 x 1140

- Minimum pit 130 mm.
- Minimum headroom 2500 mm.

Shaft dimensions for Auto Telescopic door type – 4 Passenger

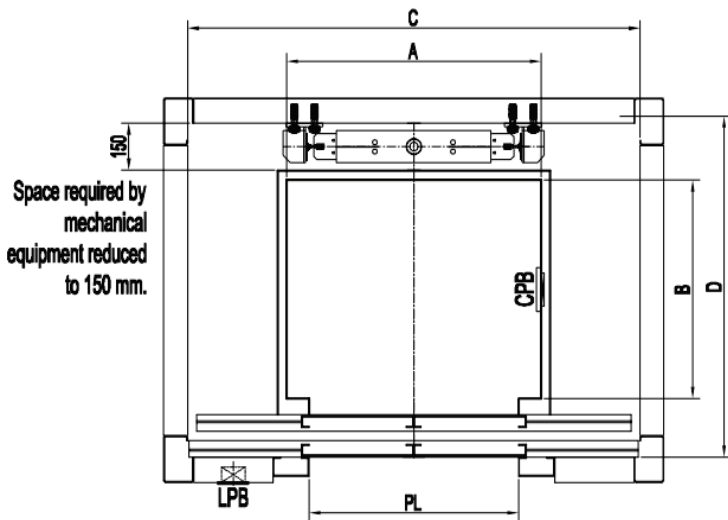

Payload [kg]	No. Pass	Car dimensions [mm]	Clear door opening [mm]	dimensions with Centre opening doors [mm]
		A x B	PL	C x D
204	3	850 x 700	700	1510 x 1070

- Minimum pit 130 mm.
- Minimum headroom 2500 mm.

Shaft dimensions for Centre Opening door type – 3 Passenger

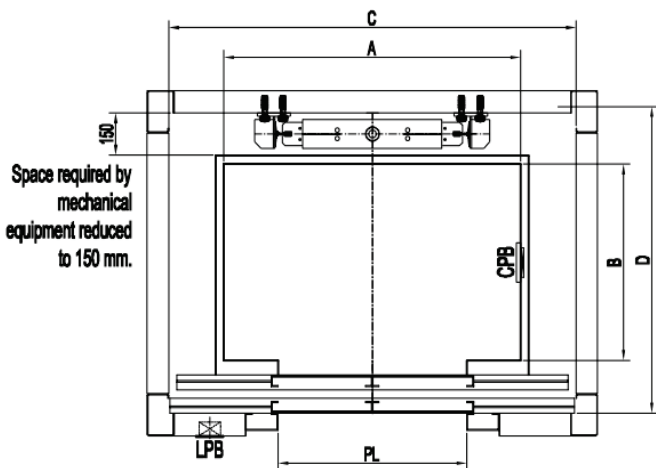

Payload [kg]	No. Pass	Car dimensions [mm]	Clear door opening [mm]	dimensions with Centre opening doors [mm]
		A x B	PL	C x D
272	4	1100 x 700	700	1510 x 1070

- Minimum pit 130 mm.
- Minimum headroom 2500 mm.

Shaft dimensions for Centre Opening door type – 4 Passenger

Non-contractual information subject to conditions of use. Shaft dimensions refer to orthogonal spaces. For feasibility of solution, not present in the table, please contact GMV Sales Office.



## GMV INDIA PRIVATE LIMITED

Office:

201, 2nd Floor – LEONARDO OFFICE,

Building type A,

Hiranandani Estate,

Ghodbunder Road,

Thane (W) – 400607

Tel.: +91 22 41005236

Tel.: +91 7506336730

e-mail: [info@gmv-india.co.in](mailto:info@gmv-india.co.in)

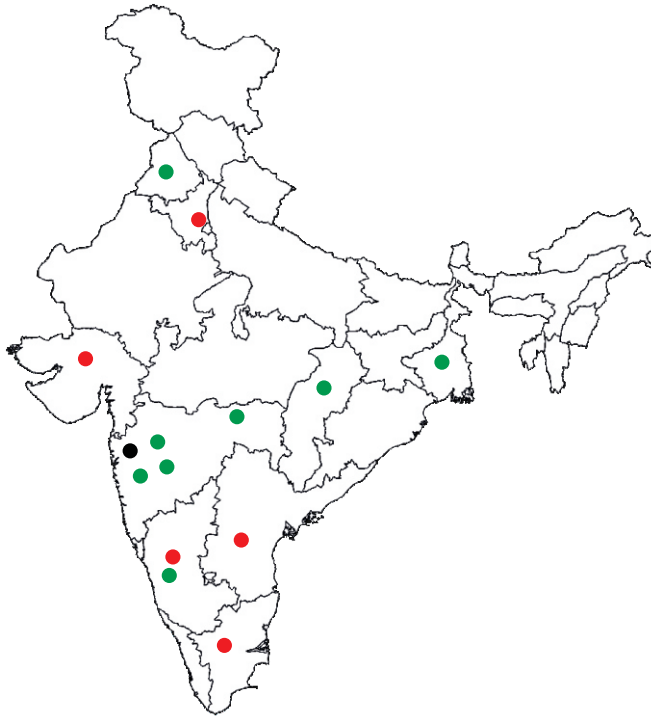

### For More details

Please Log On to  
[www.gmv-india.co.in](http://www.gmv-india.co.in)

### GMV India's Network

- Head Office in Mumbai
- Glocal Partners
- Distributors

GMV worldwide



GMV's quality systems are certified. Furthermore, we have introduced the "6 sigma" concept as a total quality philosophy, up to the complete testing of the products.

This document is for information purposes only. We reserve the right to modify at any time the reported specifications, without notice. We recommend that you view actual samples of car finishes, as there may be slight differences to those illustrated in the brochure.